

1 Read and match. Colour and say.

1 a blue book

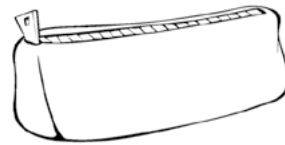

2 an orange pencil case

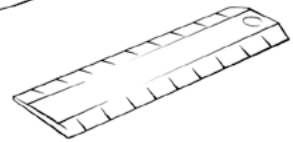

3 a brown ruler



4 a green school bag

5 a red computer

2 Read and trace.

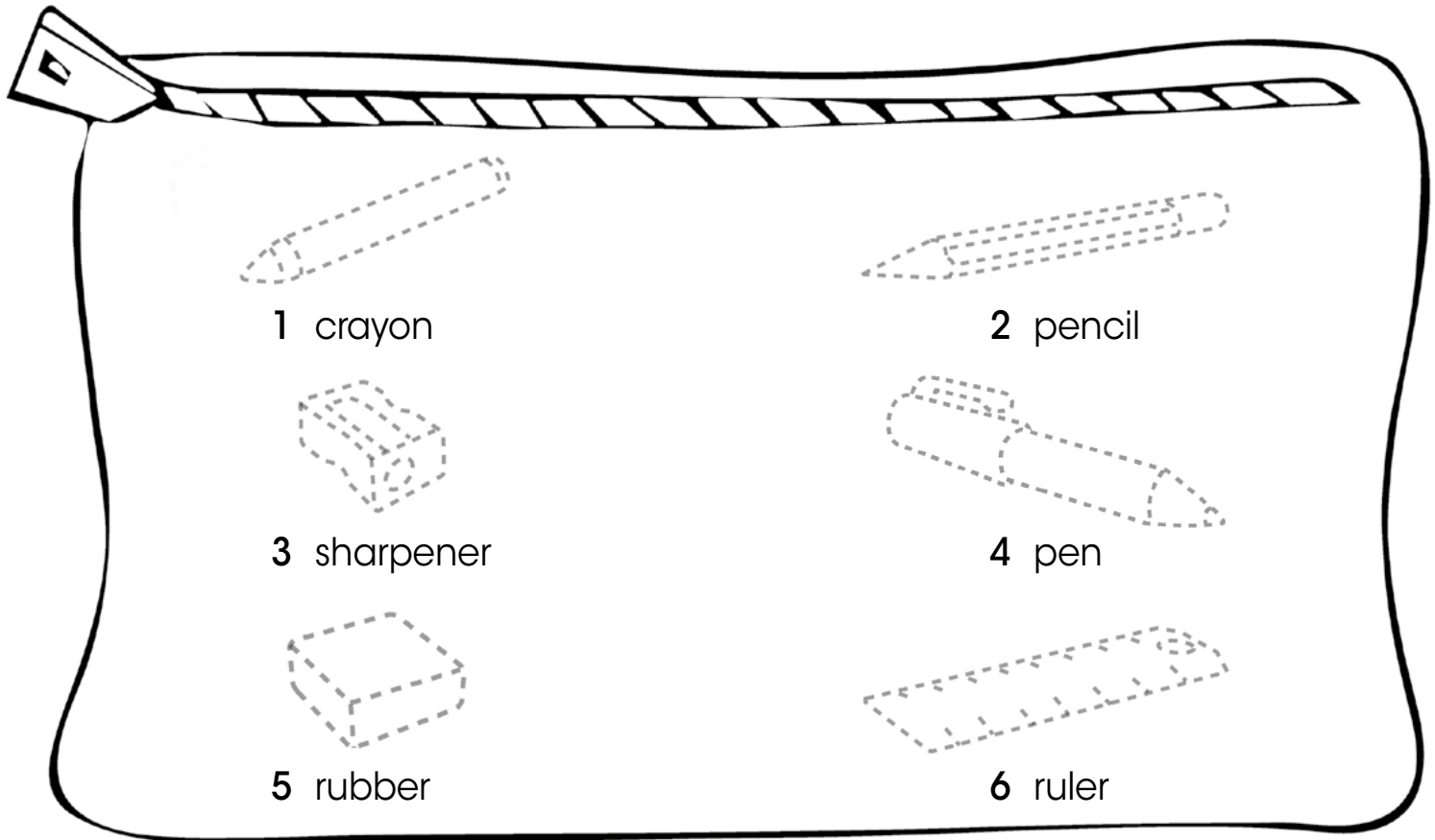

1 crayon

2 pencil

3 sharpener

4 pen

5 rubber

6 ruler



5

five



1 Read, follow and draw.

1 Where's my ruler?

2 Where's my sharpener?

3 Where's my book?

4 Where's my crayon?

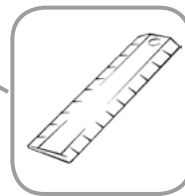

It's here.

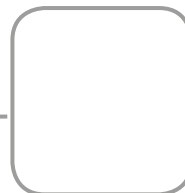

It's here.

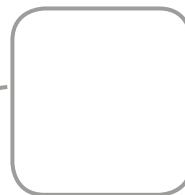

It's here.

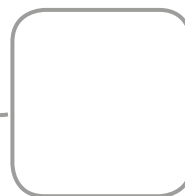

It's here.

2 **Talk Partners** Choose and circle. Act out.

Oh no! Where's my

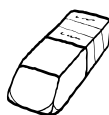
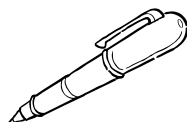

?

It's here.

And where's my

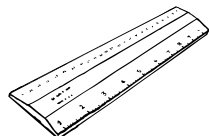

?

It's here, too. Look!

Thank you.



6

Six

After you read

1 Remember the story. Look and number.

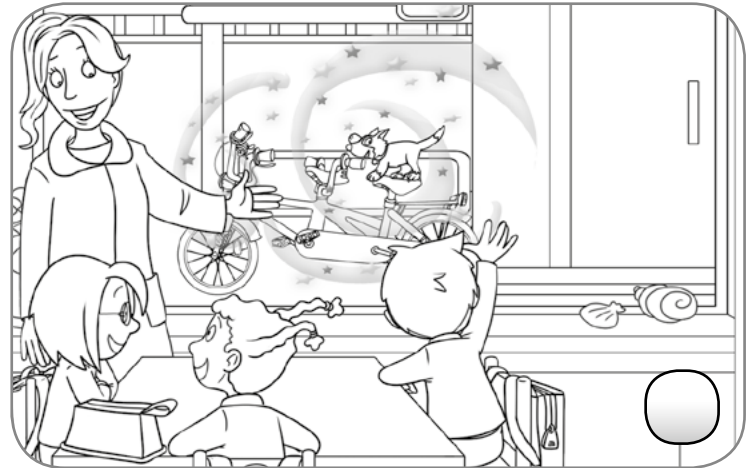
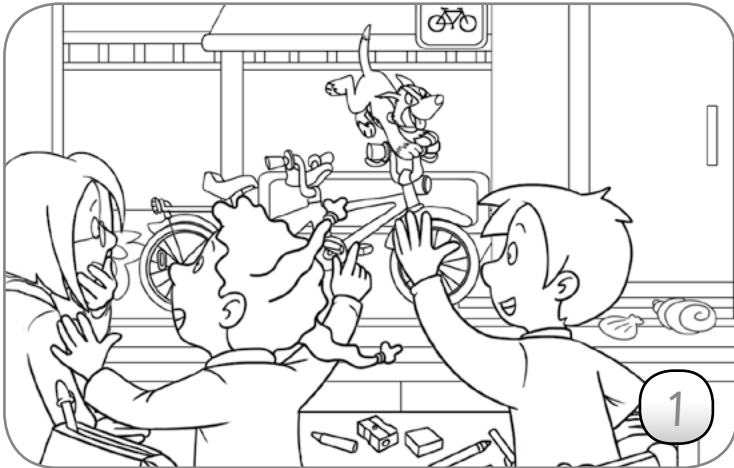
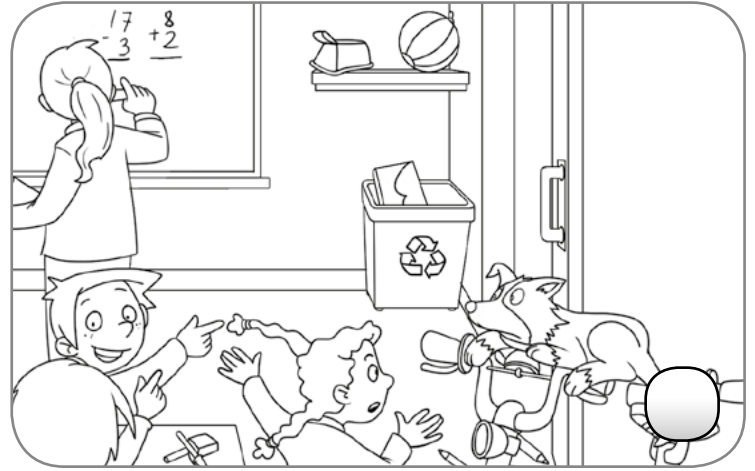

2 Read. Colour the objects in the story.

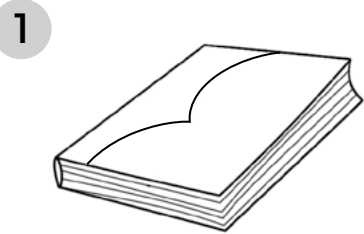

a black and white book

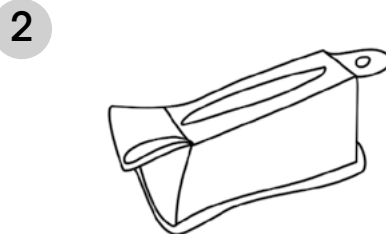

a purple pencil case

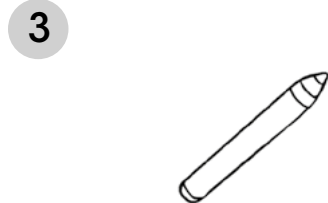

a pink crayon

1 Listen and tick (✓).  CD1 19

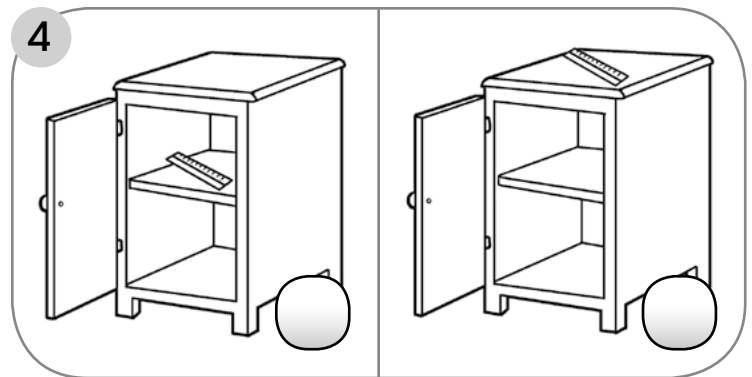
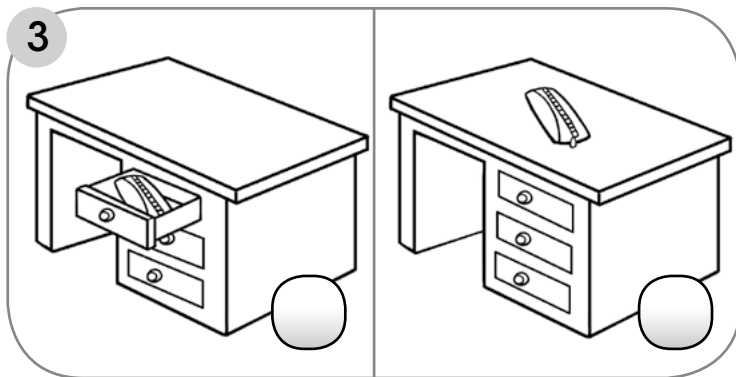
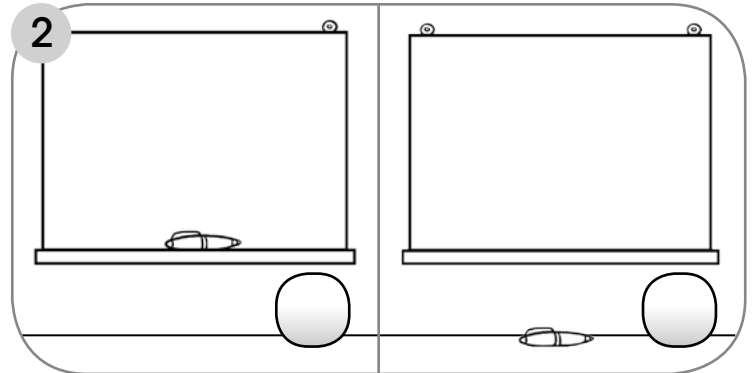
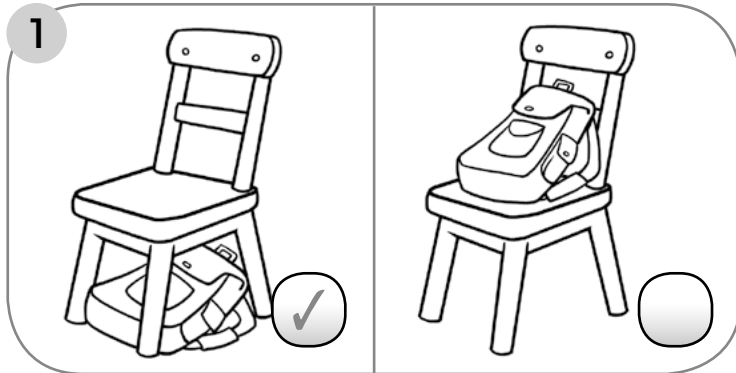

2 Read and draw.

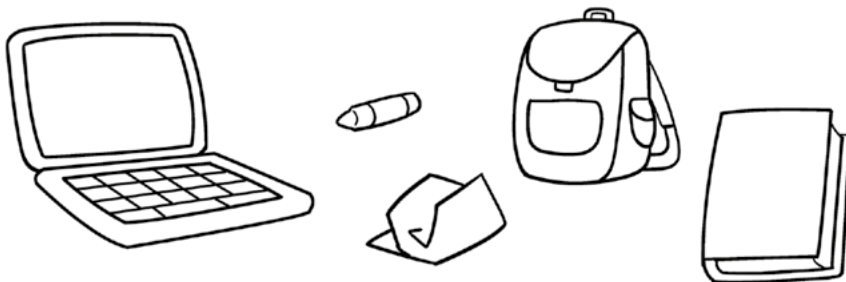

- 1 Put the book on the shelf.
- 2 Put the computer on the desk.
- 3 Put the paper in the bin.
- 4 Put the school bag under the chair.
- 5 Put the crayon in the cupboard.

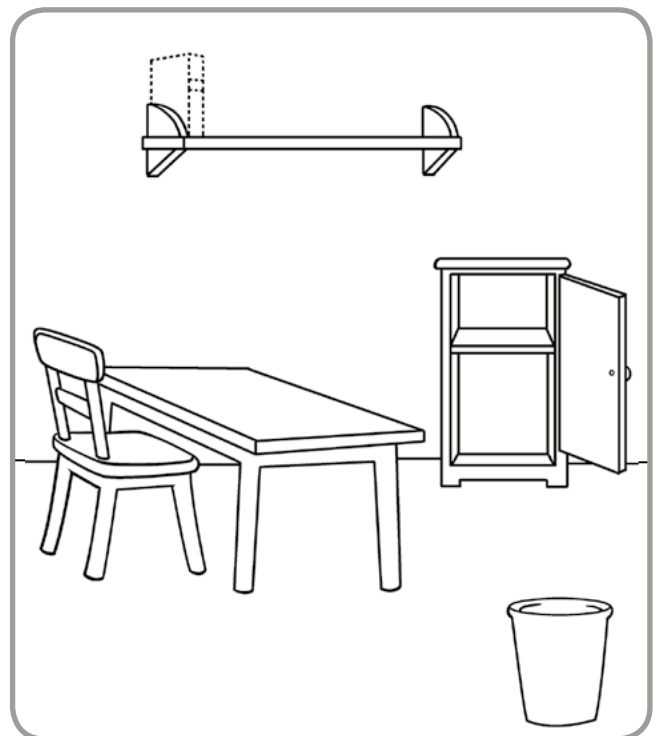





Toby's tongue twister

1 Say.

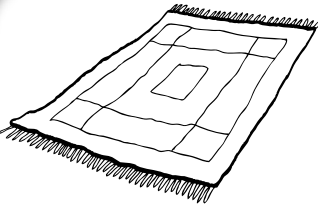
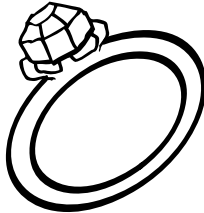
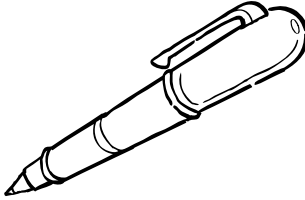
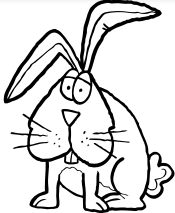

r - r - r. A red rabbit on a red ruler.

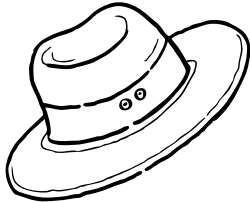
2 Colour the words that begin with 'r'. Say.

 rug	 ring	 pen	 rabbit
 rat	 hat	 read	 run

3 **Talk Partners** Play *Fast finger!* in pairs.

Rubber!

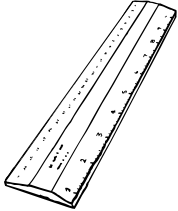

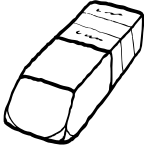



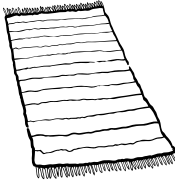





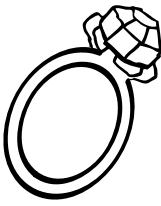







Here!

Play Fast finger!: Pupils play with their Talk Partner. Pupil A says a word and Pupil B points to the picture as quickly as possible. They swap roles and repeat. They continue playing until they have found all the words.

10 ten

 9 nine

1 Listen and number. Say.  CD1 23



We sing songs.



We listen to the head teacher.



We clap our hands.



We play music.

 **Think about your culture**



What do you do at school?

2  Read and tick (✓). Draw and say.

- 1 I listen to the head teacher.
- 2 I play music.
- 3 I sit on the floor.
- 4 I sing songs.

After you read



Text type: **A classroom poster**

1 Read and number.

- 1 Listen to others.
- 2 Put your hand up to speak.
- 3 Work quietly.
- 4 Sit down on your chair.
- 5 Walk in the classroom.
- 6 Tidy up your things.



2 Look and colour the good children.

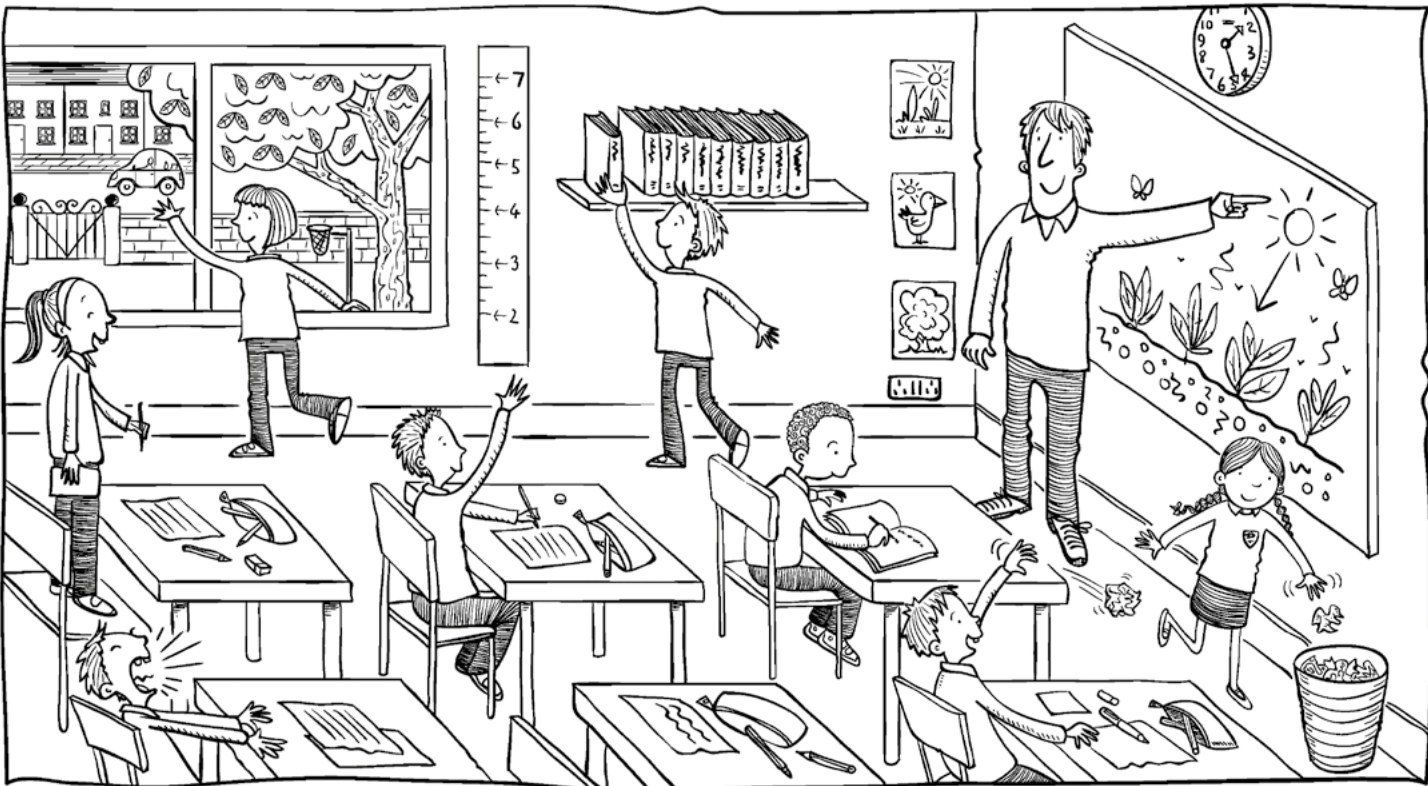

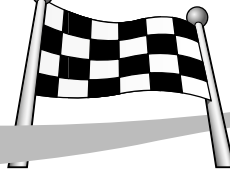

1 What's missing? Look, circle and draw.

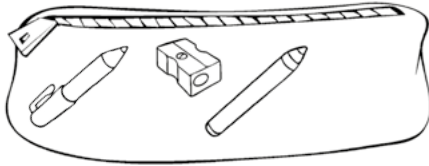

1 Where's my **ruler** / **crayon**?

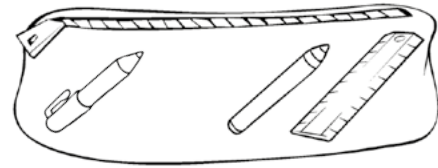

2 Where's my **sharpener** / **pen**?

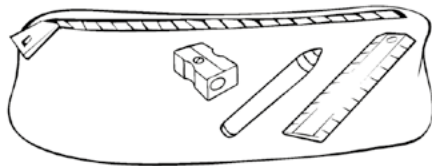

3 Where's my **ruler** / **pen**?

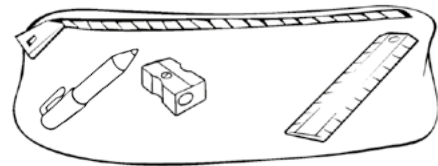

4 Where's my **crayon** / **sharpener**?

2 Match and circle.

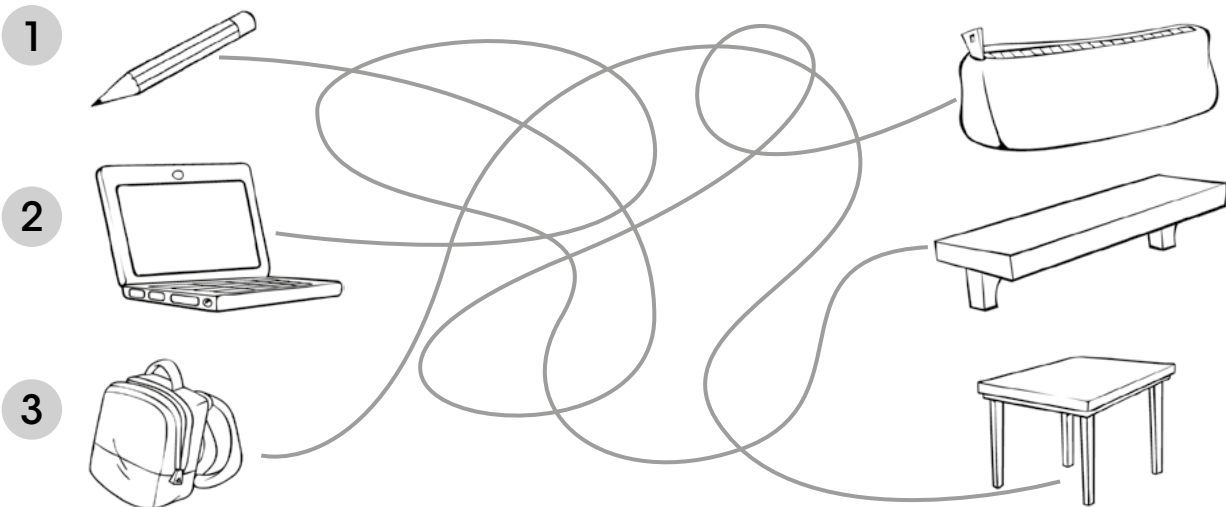

1 Put the **pencil** / **computer** in the **pencil case** / **school bag**.

2 Put the **school bag** / **computer** on the **desk** / **shelf**.

3 Put the **pencil case** / **school bag** under the **shelf** / **desk**.

3

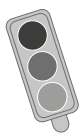

My

progress

Use your traffic light. Listen to the teacher and point.

Key for Activity 3: 1. I can say the names of classroom objects. 2. I can ask *Where's my pen?* 3. I listen to the teacher and my friends. 4. I put my hand up to speak. 5. I tidy up my things.



7

Seven



1 What's missing in the school bag? Listen and circle.

1					
2					
3					
4					



What's in your school bag?

2 Read and tick (✓).
Draw, point and say.











- 1 book
- 2 snack
- 3 pencil case
- 4 water
- 5 ruler



3 three



Let's practise spelling!

	Look	Read	Trace
1		book	book
2		pen	pen
3		rubber	rubber
4		pencil	pencil
5		ruler	ruler
6		crayon	crayon
7		sharpener	sharpener
8		computer	computer
9		school bag	school bag
10		pencil case	pencil case



eight