

3

At school



Vocabulary

1  1.16 Listen and point.

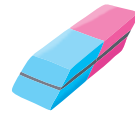
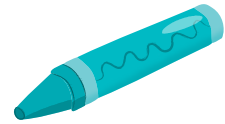

2  1.16 Listen again and say.

3  Look at the picture. Find, count and match.

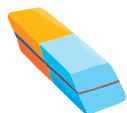
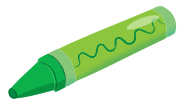

3

4

5

6

7

10

4  1.17 Sing and act out. **Be a star!** 

Lesson 3 Grammar



1 1.18 Listen and follow.



2 1.18 Listen again. Circle blue for Jack and circle red for Maya.

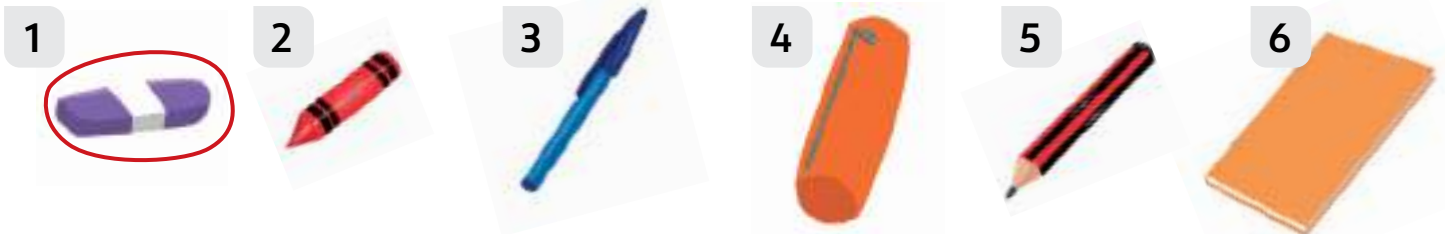

3 Work in groups. Act out the story.

Be a star!

Lesson 4 Grammar

1  1.19 Listen and match.

1



2



3



4



2 Complete and colour. Then say.

Be a star! 

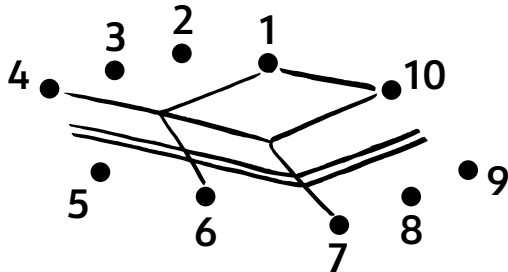
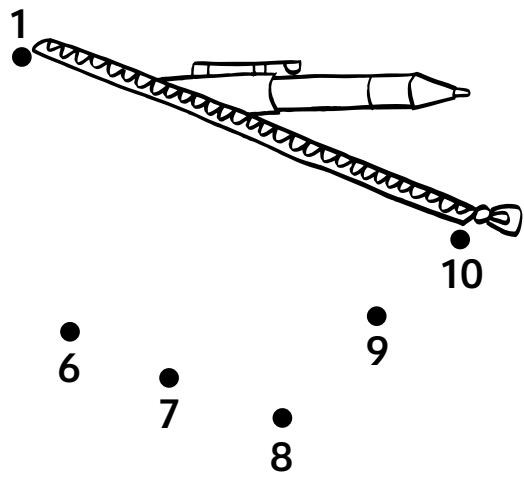
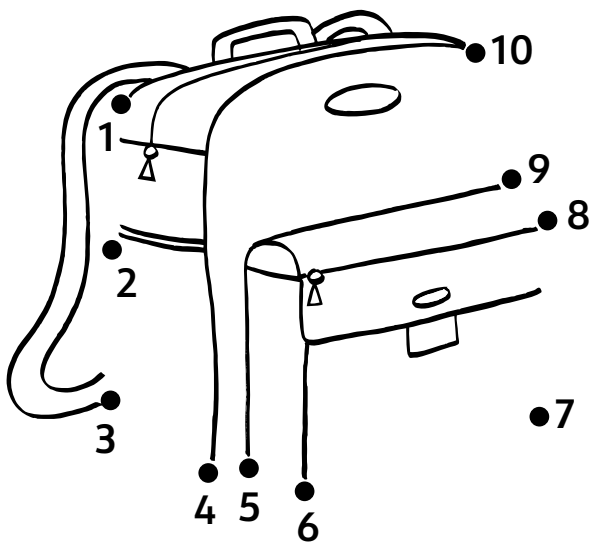



Lesson 5 / Speaking

1  1.20 Listen and say.

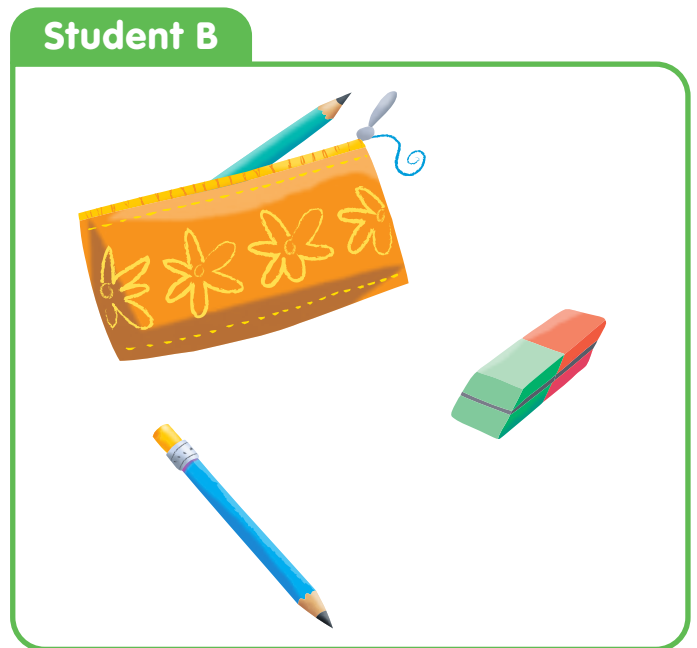
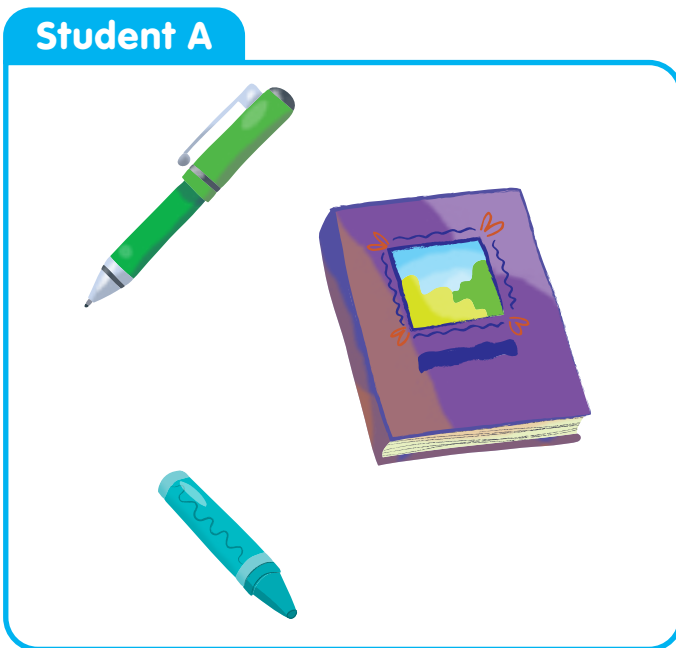

2  Work in pairs. Talk about the classroom objects.



3  Now it's your turn. Tell a friend about your classroom objects.

Be a star! 

Lesson 6 / Listening

1  1.21 Listen and circle.

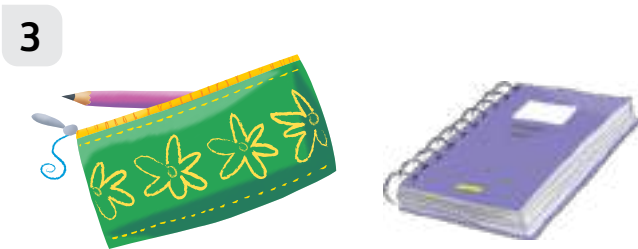
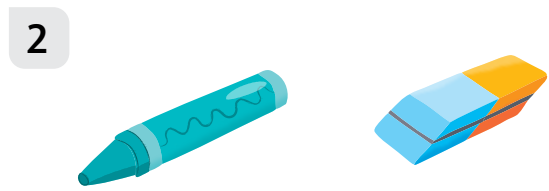
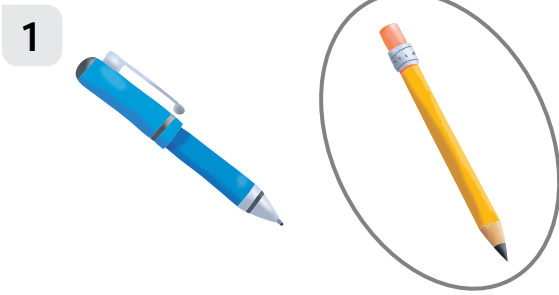

2  1.22 Listen and tick (✓) the correct classroom objects.

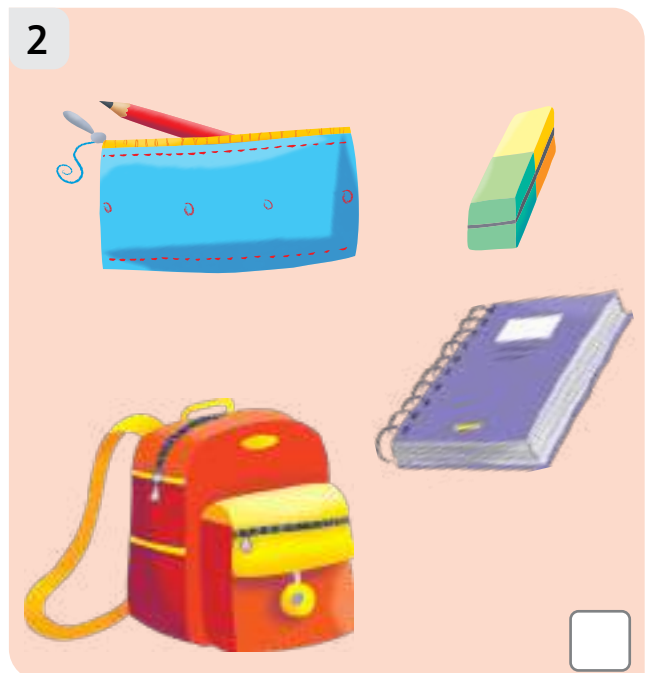

3  Work in pairs. Find classroom objects. Act out. **Be a star!** 

Lesson 7 / Game

1 Make a game.



2  Work in pairs. Play. **Be a star!** 



Lesson 8 Review

1 Find and circle. Then say.

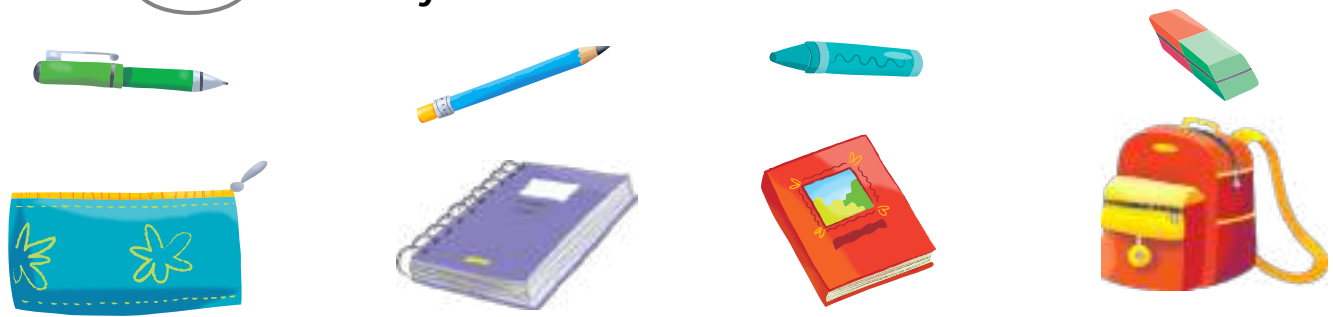

2  Work in pairs. Play *Memory*. Say the classroom objects. **Be a star!** 

